



Owner's Guide
CA200

TABLE OF CONTENTS

Thank you for purchasing the *Ionic Pro® Compact* ionic air purifier and congratulations on taking this important step in improving the quality of air in your home, office or other indoor environments. Customer satisfaction is our number one goal. Your *Ionic Pro® Compact* ionic air purifier is a premium air purifying appliance which comes with a limited one-year warranty.

Enjoy your *Ionic Pro® Compact* ionic air purifier and visit our website for more exciting quality products and upgrades at www.ionicpro.com.

Safety Instructions	2
Important Warnings	4
Main Parts	4
Operating the Ionic Pro® Compact Ionic Air Purifier	6
Getting Ready	6
Controls/Settings	7
Operation	8
Cleaning & Maintenance	9
To Clean the Collection Blades	10
To Clean the Internal Ionizing Wires	11
Deep Cleaning	12
Cleaning External Surfaces	12
Trouble-Shooting	13
More Things You Should Know	14
Ozone and Your Health	14
Warranty	15
Arbitration Agreement	16

SAFETY INSTRUCTIONS

EXTREMELY IMPORTANT INFORMATION: Safety precautions should always be used when operating this or any electrical appliance. Decrease the risk of electrocution, electric shock, injury or fire by reading and following all the warnings below:

- Use only as described in this Ionic Pro® Compact ionic air purifier manual. To reduce the risk of electric shock, do not attempt to service the product in any way other than in the manner described in the Cleaning and Maintenance section of this manual.
- Do not use the Ionic Pro® Compact ionic air purifier outdoors.
- Do not use the Ionic Pro® Compact ionic air purifier in bathrooms or other humid environments, near fireplaces or in areas where flammable or combustible vapors or products may exist.
- Ionic Pro® Compact ionic air purifier operates at 120v AC and 60Hz only.
- To reduce the risk of electric shock, this product has a grounding-type plug that has a third grounding pin. This plug will fit only into a grounding-type power outlet. If the plug does not fit into the outlet, contact qualified service personnel to install the proper outlet. Do not alter the plug in any way.
- Always turn off all controls before unplugging the Ionic Pro® Compact ionic air purifier from outlet.
- Always turn off and unplug this product from outlet before cleaning the collection blades.
- Always turn off this product when not in use.
- Never touch the internal parts, such as electrodes, ionizing wires, or any internal part within the Ionic Pro® Compact ionic air purifier with any object.
- Do not open the outer casing of the Ionic Pro® Compact ionic air purifier. Attempting to open the unit will cause the warranty to be voided and could cause serious personal injury to the user and/or result in considerable damage to the unit.
- Do not place the Ionic Pro® Compact ionic air purifier's cord near a heated surface.
- Never operate the Ionic Pro® Compact ionic air purifier if the plug or cord is damaged or appears damaged. Only qualified service personnel should ever replace or attempt to replace a damaged power cord.
- Never use the power cord to pick up, carry, drag, pull, or lift the Ionic Pro® Compact ionic air purifier. Do not pull the cord against or around sharp corners and edges. This could result in injury to the user or damage to the cord.
- Always remove the plug from its power outlet by holding onto the plug itself and pulling gently.
- Never pull on the cord itself to unplug it from its power outlet.
- Use care when operating the Ionic Pro® Compact ionic air purifier by keeping all fingers, body parts, hair, loose clothing and jewelry away from openings.
- Never touch the Ionic Pro® Compact ionic air purifier or its plug when your hands are wet.
- The Ionic Pro® Compact ionic air purifier is an electrical appliance. Adult supervision is required when operating the Ionic Pro® Compact ionic air purifier in the presence of children.
- Do not touch the metal blades until after discharging residual electricity by touching blades to an electrical ground such as a water pipe or metal faucet.
- The collection blades should be inspected frequently and cleaned regularly to prevent excessive accumulation that may result in an electrical flashover or risk of fire.

IMPORTANT WARNINGS

Main Parts

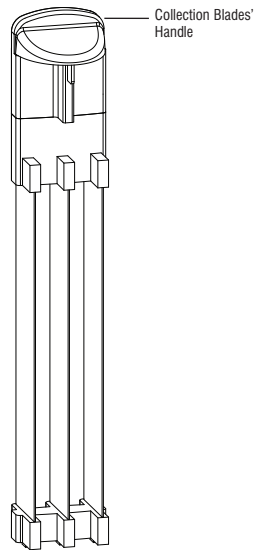

A. COLLECTION BLADES

TOP OF COLLECTION BLADES.

See A for view of collection blades alone.

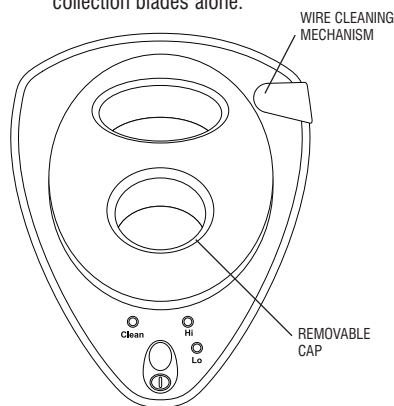

B. OPERATING PANEL

Before using your Ionic Pro® Compact ionic air purifier, please read the following important information.

First, please look at the “Main Parts” diagram and locate the part labeled A.

These are the collection blades and are a vital part of this amazing ionic air purifying system.

The collection blades are where unhealthy pollutants, allergens and irritants are trapped when the Ionic Pro® Compact ionic air purifier is in proper working condition and in use.

The Ionic Pro® Compact ionic air purifier is designed to run quietly and requires very little time and effort to maintain in proper working condition. If you hear excessive noise or static coming from your Ionic Pro® Compact ionic air purifier, it generally indicates that the product needs to be cleaned. Turn off your Ionic Pro® Compact ionic air purifier, unplug the cord and carefully follow the cleaning instructions in the “CLEANING & MAINTENANCE” section of this manual.

If the product is still making excessive noise after cleaning and thoroughly drying the collection blades and re-inserting them as described in the “CLEANING & MAINTENANCE” section of this manual, turn off and unplug the unit. After you have turned off and unplugged

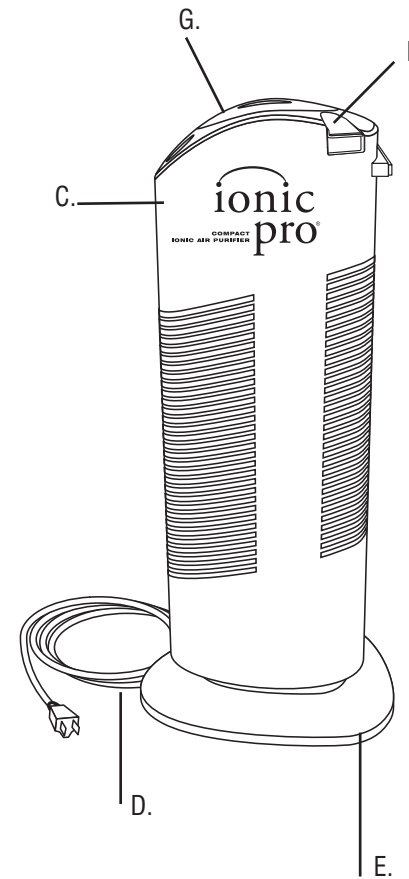

C. OUTER CASE HOUSING

D. AC CORD

E. BASE

F. WIRE CLEANING MECHANISM

G. REMOVABLE CAP

the unit, see Diagram B or F for the location of the Wire Cleaning Mechanism. Lift and lower the Wire Cleaning Mechanism three to four times to thoroughly clean the internal ionizing wires (see Diagram H in the “CLEANING & MAINTENANCE” section). This movement helps to scrape free particles from the internal ionizing wires. To keep your Ionic Pro® Compact ionic air purifier working properly, it will be necessary to clean the collection blades after every month of use and the internal ionizing wires after every two weeks of use (see “CLEANING & MAINTENANCE” and “DEEP CLEANING” section of this manual for the proper techniques).

WARNING: After cleaning the collection blades (see “CLEANING AND MAINTENANCE” section) with soap and water, allow at least 24 hours for the collection blades to dry thoroughly before inserting them back into the unit. Water can easily get trapped along the collection blades’ many surfaces and edges and damage could result if there is any moisture on the collection blades.

You will need to clean your Ionic Pro® Compact ionic air purifier more often if it has been exposed to heavy pollution.

Do not place Ionic Pro® Compact ionic air purifier near a fireplace. Even if a fireplace is not in use, chimney dust and soot may circulate through the Ionic Pro® Compact ionic air purifier and then re-circulate and leave a residue on the unit and surrounding areas. We recommend not placing the Ionic Pro® Compact ionic air purifier anywhere near candles or oil lamps. If you intend to use candles or oil lamps near the Ionic Pro® Compact ionic air purifier despite this warning, make sure that the wicks are cut to no more than a quarter inch to cut down on smoke production.

OPERATING THE IONIC PRO® COMPACT IONIC AIR PURIFIER

Getting Ready

Locate a level surface on which to place your Ionic Pro® Compact ionic air purifier and a grounded 120v outlet (follow warnings described in the “SAFETY INSTRUCTIONS” section of this manual). Position your Ionic Pro® Compact ionic air purifier at least one foot (12 inches) from the wall.

Plug in the unit. *You are now ready to turn on your Ionic Pro® Compact ionic air purifier!*

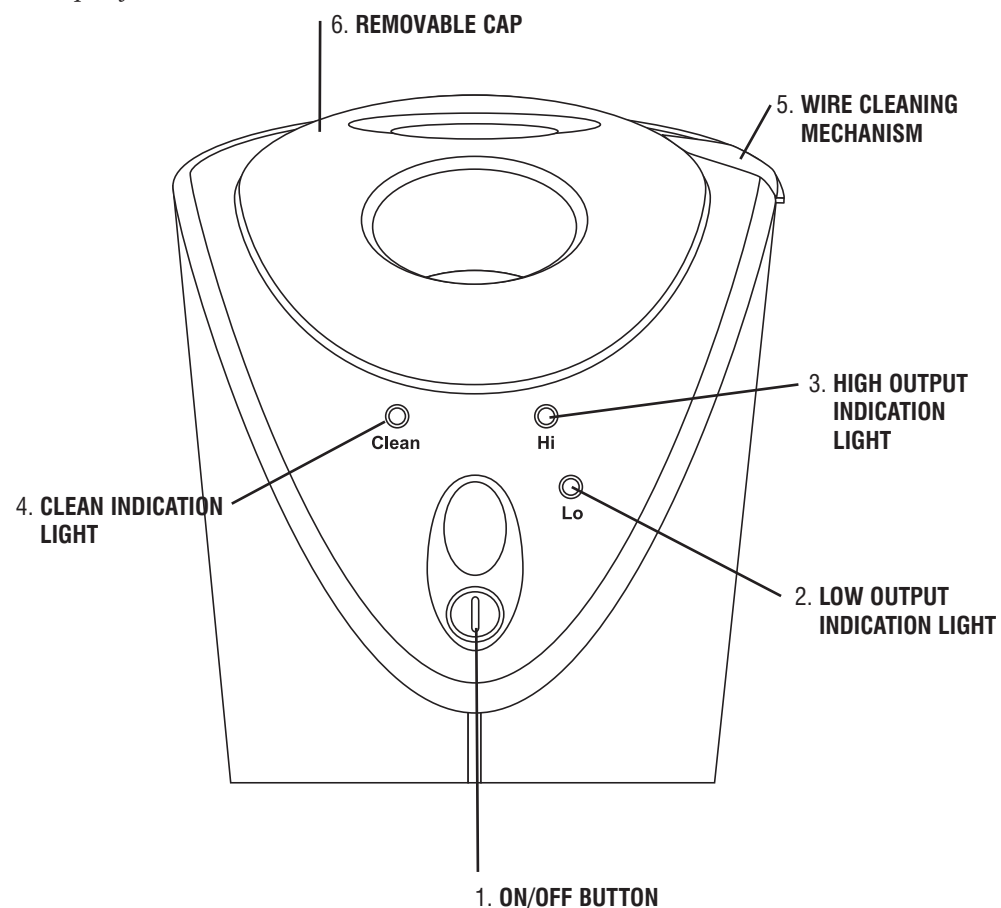

Controls/Settings

- 1. ON/OFF BUTTON**
Turns unit on and off.
- 2. LO**
(low output indication light)
At this setting, the unit will cycle ON and OFF. It will cycle ON for approximately 25 seconds, and then rest for 25 seconds. This cycling will continue as long as the unit is in LO mode.
- 3. HI**
(high output indication light)
At this setting, the unit stays ON continuously.
- 4. CLEAN**
(indication light)
This red light goes on when your Ionic Pro® Compact ionic air purifier needs to be cleaned, or the unit is experiencing some other problem. See the “CLEANING & MAINTENANCE” and “TROUBLE-SHOOTING” sections.
- 5. WIRE CLEANING MECHANISM**
This is used to clean the internal ionizing wires. See “CLEANING & MAINTENANCE” for full details.
- 6. REMOVABLE CAP**
Lift off the Removable Cap to locate collection blades for cleaning (as described in “CLEANING & MAINTENANCE” section).

CLEANING & MAINTENANCE

Operation

Set up the Ionic Pro® Compact ionic air purifier as described in “Getting Ready”. Press the ON/OFF button to activate your ionic air purifier and get ready to enjoy clean, ionized air that cycles through pre-programmed run/rest intervals according to the setting you select.

The Ionic Pro® Compact ionic air purifier automatically defaults to the HI (high/maximum output) setting whenever the unit is turned on.

Press the ON/OFF button one more time to select the LO (low) output setting to enjoy intermittent run/rest periods.

Press the ON/OFF button a third time to turn the unit off.

The indicator LEDs light up to indicate your current setting (LO, HI).

Clean Light:

The red CLEAN light will turn on and the unit will shut down if cleaning is overdue.

The Ionic Pro® Compact ionic air purifier’s collection blades must be cleaned after month of use and the internal ionizing wires must be cleaned after every two weeks of use (see “CLEANING & MAINTENANCE” for full directions). Once the collection blades are properly cleaned, thoroughly dried and re-inserted into your Ionic Pro® Compact ionic air purifier *and* the internal ionizing wires are properly cleaned, normal operations should continue. If not, see “DEEP CLEANING” and “TROUBLE-SHOOTING.”

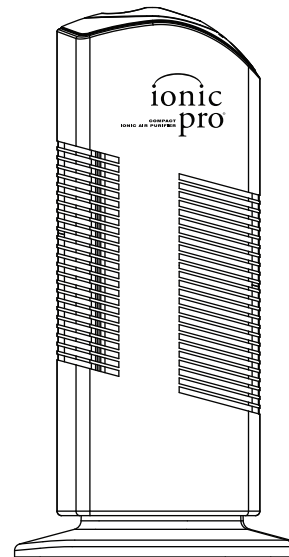

UNIT

With very little effort, the Ionic Pro® Compact ionic air purifier delivers cleaner, fresher, healthier air to your indoor environments.

Keep your Ionic Pro® Compact ionic air purifier functioning properly by cleaning the collection blades after every month of use as recommended. The internal ionizing wires are an important part of the Ionic Pro® air purifying system and need to be cleaned after every two weeks of use or if your unit starts to make a buzzing noise (see “TO CLEAN IONIZING WIRES” and “DEEP CLEANING” sections).

More frequent cleaning is often required if your Ionic Pro® Compact ionic air purifier is new or if you place it in a different location. Exposing your Ionic Pro® Compact ionic air purifier to candle/oil lamp/fireplace soot and smoke is not recommended and will require the collection blades to be cleaned after every exposure (see “IMPORTANT WARNINGS”).

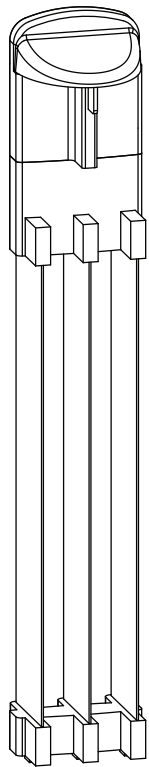

COLLECTION BLADES

HELPFUL TIPS: Remember to clean your Ionic Pro® Compact ionic air purifier every month and any time the red **CLEAN/FAULT** light comes on or whenever you hear your unit begin to make excessive noise.

To Clean the Collection Blades

Turn off and unplug your Ionic Pro® Compact air purifier. Let the unit rest a minute.

Next, lift off the removable cap and pull up on the collection blades' handle to slide the collection blades out of the top of your Ionic Pro® ionic air purifier.

Do not touch the metal blades until after discharging residual electricity by touching blades to an electrical ground such as a water pipe or metal faucet. Wipe away the trapped particles collected on the three blades with a slightly damp sponge or cloth. If you use a slightly damp cloth to clean the blades, it is possible the collection blades will be completely dry within two to three hours. Always allow the collection blades to dry thoroughly before resuming use.

IMPORTANT: To avoid damaging your Ionic Pro® Compact ionic air purifier, make sure the collection blades are completely dry and free of all moisture and that your Ionic Pro® Compact ionic air purifier is turned off and unplugged before attempting to re-insert the collection blades.

If you have used soap and water to clean the collection blades, wait at least 24 hours to ensure that they are thoroughly dry before re-inserting them into your Ionic Pro® Compact ionic air purifier.

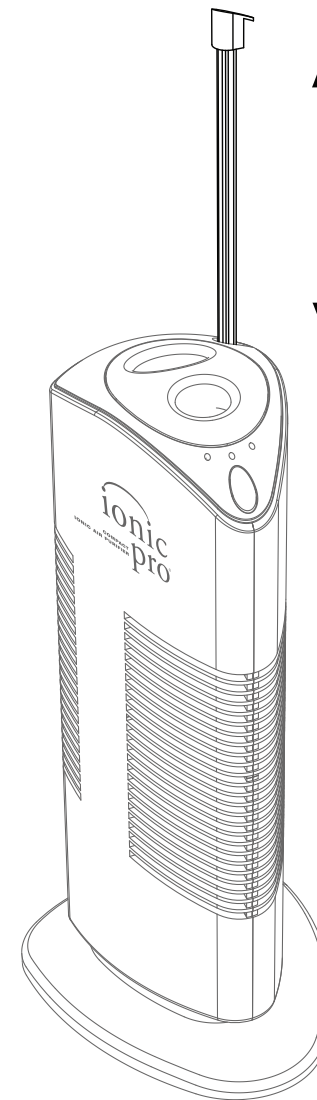

H. CLEANING WIRES

To Clean the Ionizing Wires

The internal ionizing wires need to be cleaned after every two weeks of use. There is a Wire Cleaning Mechanism used to clean the internal ionizing wires which you slide up and down to scrape off particle residue, (see Diagram B of the Operating Panel to locate the Wire Cleaning Mechanism). Lift and lower the Wire Cleaning Mechanism three or four times to thoroughly clean the ionizing wires (see Diagram H).

REMEMBER TO ALWAYS RETURN THE WIRE CLEANING MECHANISM TO ITS ORIGINAL POSITION BEFORE ATTEMPTING TO RESUME USE OR THE UNIT WILL NOT FUNCTION.

TROUBLE-SHOOTING

Deep Cleaning

Noisy functioning (audible loud buzzing sound) is a sign that your Ionic Pro® Compact ionic air purifier is overdue for a complete clean-up of the collection blades and the internal ionizing wires. The internal ionizing wires must be kept clean to ensure silent and normal operation.

For deep cleaning, follow both the “TO CLEAN THE COLLECTION BLADES” & “TO CLEAN IONIZING WIRES” sections.

IMPORTANT: MAKE SURE THE THOROUGHLY CLEANED AND DRIED COLLECTION BLADES ARE PROPERLY INSERTED, THE REMOVABLE CAP IS BACK IN ITS ORIGINAL POSITION, AND THE WIRE CLEANING MECHANISM IS BACK IN ITS ORIGINAL POSITION BEFORE RESUMING USE—OR THE UNIT WILL NOT FUNCTION.

Cleaning External Surfaces

Over time, some particles and dust may accumulate on the external surfaces of your Ionic Pro® Compact ionic air purifier. If this happens, turn off and unplug the unit. Mix one ounce of laundry bleach with five ounces of water and apply sparingly with a sponge to wipe the outer case surfaces. Do not allow water to slip into the internal parts of the Ionic Pro® Compact ionic air purifier as this could damage its functioning and may result in injury to you. Allow the unit to dry for at least 24 hours before resuming use.

TROUBLE	REASON	TROUBLE-SHOOTING
Indication/Setting light not on	Machine is unplugged. ON/OFF button has not been pressed.	Check to see if plug is loose. Press the ON/OFF button.
Red CLEAN light is on	Too much dust has accumulated. Collection blades are jarred or removed suddenly. Red light may go on if the unit just needs to be “reset”	Turn off, unplug and clean using instructions from the “Deep Cleaning” section. Remove and re-insert collection blades and press “on” button to reset. Press “on” button to reset.
Excessive noise generated*	Too much dust has accumulated or internal parts are wet.	Clean and dry blades and ionizing wires thoroughly.* Keep the machine dry.
Collection blades do not go back in	Improper orientation	Reverse blade orientation
Indication light does not go on	Collection blades are not completely inserted. Wire Cleaning Mechanism is not completely inserted	Check to see that the blades are completely seated in housing. Check to see that Wire Cleaning Mechanism is completely seated in housing.

*See “Cleaning & Maintenance” section

MORE THINGS YOU SHOULD KNOW

Ozone and Your Health

After you activate your Ionic Pro® Compact ionic air purifier, you may notice a new clean scent.

Ozone is the scent you are smelling. Ozone is a combination of three oxygen atoms. The Ionic Pro® Compact air purifying system utilizes an ionizing process which results in very low ozone emission.

The Ionic Pro® Compact ionic air purifier complies with U.S. safety requirements for low ozone emission (less than 50 parts per billion) and meets the UL867 standard for consumer products. UL867 is the U.L. standard for safety for electro-static air cleaners.

Individuals with a history of respiratory disease, asthma, heart disease, lung disease, breathing problems or concerns about ozone should ask their doctor whether the concentrations of ozone generated by this or other commercial ionic air purifiers are appropriate for their specific health needs.

LIMITED ONE YEAR WARRANTY

Your Ionic Pro® Compact ionic air purifier is warranted to be free from defects in materials and workmanship for one year from the original purchase date. Should the product have a defect in materials or workmanship, we will repair or replace it without charge to you (a shipping and processing fee may apply). To obtain service under warranty, simply call our Customer Service Center toll-free at **1.800.875.8577**.

This warranty does not cover damage caused by accident, misuse or any use other than as intended and described in this product manual, or damage resulting from failure to maintain and clean this product as specified in this product manual. This warranty applies only to the original purchaser of the Ionic Pro® Compact ionic air purifier.

Contact Info for Warranty Service:

Ionic Pro
P.O. Box 3456
Los Angeles, CA 90078
1.800.875.8577
www.ionicpro.com

© 2005-2007 Ionic Pro, LLC. All Rights Reserved.
U.S. Patent Nos. D495,042; D505,488; D522,116; 6,855,190;
6,946,103; and 6,977,008.
Chinese Patent No. ZL03353322.9; ZL200420006826.0;
ZL200420077199.X, and ZL200620004930.5.
Hong Kong Patent Nos. HK1063973; HK1066437; and HK1082896.
Additional patents pending.

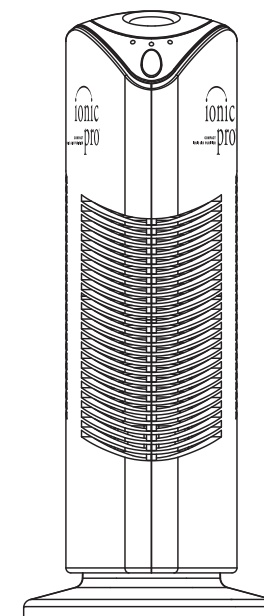



IONIC AIR PURIFIER
ionicpro®

IPMNC052208